



Green Sky White Paper

Green Innovations of Antennas



Content

01	Introduction	01
02	Maximum Efficiency, Green Sky	02
	2.1 Energy Saving	02
	2.2 Green Deployment	03
	2.3 Green Manufacturing	04
03	Innovation in Three Directions Towards the Green Sky Targets	05
	3.1 Architecture Innovation	05
	3.2 Process Innovation	09
	3.3 Form Innovation	10
04	Targets of Green Sky Program in 2025	13



01 Introduction



Green growth and environmental protection are the key to the sustainability of the global economy. As global climate change escalates, the synergy between economic progress and natural boundary has become a worldwide issue, and carbon neutrality is now a common priority for all countries. Scientific studies carried out by the United Nations concluded that global temperature rise must be controlled to less than 1.5 °C if the world hopes to avert the worst effects of climate change, calling for greater urgency to achieve the Paris Agreement targets.

Keeping global warming within the 1.5 °C threshold raises tough challenges for global economies. It requires concerted efforts from governments, industries, transportation, energy, agriculture, and many other fields to urgently transform economic development from traditional patterns to green paradigms. To fulfill this target, the ICT industry takes on the pioneering responsibilities for a green economy.

The green-oriented innovations of wireless networks require end-to-end collaboration of network devices. As an essential component that transmits and receives signals on wireless networks, antennas play an important role in saving energy and reducing emissions from networks. This white paper explores the targets and directions of technology innovation for base station antennas to promote green development of wireless networks.



To effectively transmit and receive signals, antennas are generally installed at heights, such as on towers and rooftops, where few obstacles are in the way of signal propagation. Visually, base station antennas are always located in the sky. With this inspiration, this white paper is named the Green Sky White Paper.

Taking into account the characteristics and application scenarios of antennas, this white paper explains the targets of antennas' green innovations from three aspects: energy saving, green deployment, and green manufacturing.

2.1 Energy Saving

Energy saving has become one of the most discussed topics of green development. Antennas, especially passive antennas, do not directly consume DC or AC electric energy, leaving them easily overlooked when energy saving is discussed. However, as unique devices that convert between radio frequency (RF) energy and electromagnetic waves, antennas transmit the RF energy to mobile devices. The efficiency in which the antennas convert energy has a significant bearing on the power consumed by base stations.

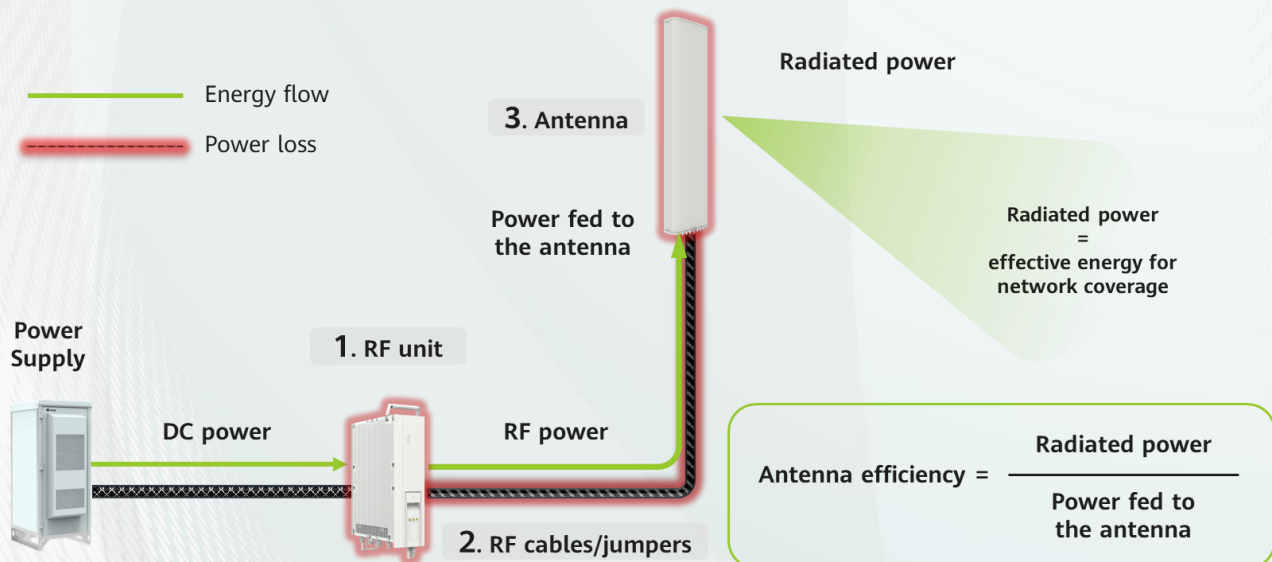

As illustrated in the figure, an RF unit feeds the RF energy to an antenna through RF cables (feeders or jumpers), and the antenna radiates the energy electromagnetic waves. In practice, an antenna cannot completely convert the RF energy into electromagnetic waves. This is because some energy is lost due to return loss, insertion loss, and other losses and cannot form effective radiation. To measure the conversion performance, antenna energy efficiency is defined by the proportion of the RF energy converted into the electromagnetic wave energy. That is:

$$\text{Antenna efficiency} = \frac{\text{Power radiated by the antenna}}{\text{Power fed to the antenna}}$$

In addition, the energy loss in the cable that links an RF unit and an antenna must be considered. The level of energy loss depends on the type and length of the cable used. In some cases, the energy loss may make up as much as dozens of percentage points.

The antenna-radiated energy is the effective portion that can be used for mobile communication. As depicted above, a higher antenna energy efficiency and a smaller cable loss means that the RF device can feed less RF energy for the same coverage performance. This offers a way to reduce base station energy consumption by lowering the output power of the RF devices.

Therefore, increasing antenna energy efficiency and reducing cable loss are effective and essential to reduce the energy consumption of base stations, and are the primary tasks of antennas' green innovations.

2.2 Green Deployment

Antennas must be installed at heights to ensure effective network coverage. However, antennas are usually large in size and weight and have the following characteristics during deployment:

- ◆ High requirements on site facilities such as bearing capacity and wind load;
- ◆ The handling and installation process is a high-altitude operation, which usually requires the support of special equipment such as cranes;
- ◆ Antennas must be environmentally unobtrusive to comply with policy requirements and residents' demands.

Because of such constraints, the consumption of resources is heavy for antenna deployment.

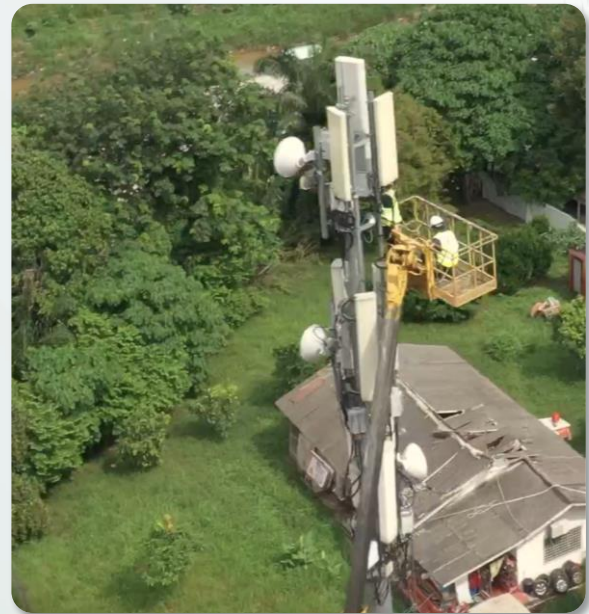

During network evolution and upgrade, antennas often need to be replaced. Scenarios such as new spectrum deployment, multi-antenna evolution, and network standard evolution may require the installation of new antennas or replacement of old ones.

Installing new antennas may entail new site deployment or existing site reinforcement, which means repeated resource consumption during site construction. Frequent replacement of antennas leads to the actual operating period of an antenna being shorter than its design life, which wastes resources.

Therefore, simplifying deployment and minimizing replacements are critical to achieve efficient network construction and evolution. This is the significance of green deployment for antennas.

2.3 Green Manufacturing

Manufacturing a product both consumes a lot of resources and produces a lot of pollution. The manufacturing process will also determine how much environmental impact the product will have. For antenna manufacturing, the materials used, energy consumed, and pollution produced are the primary concerns.

Selecting materials:

Among the materials used, plastics and various PCBs hugely impact the environment. They not only generate heavy pollution, but are also of low value in recycling, and recycling or disposing of these materials also creates severe pollution. For this reason, using as few of such materials as possible or finding substitutes must be considered early on in the design phase.

Energy-efficient manufacturing:

Manufacturing electronic products often consumes a lot of electricity. Over their lifecycle, antennas do not consume electricity or materials while they are in service. As such, the largest amount of power consumed is the manufacturing process. Optimizing the energy consumption of manufacturing antennas is critical to reduce its carbon emissions throughout the antennas' lifecycle.

Reducing pollution in manufacturing:

Conventional manufacturing generates waste water, exhaust gas, and physical pollutants, which pose a tough challenge for environmental governance. Using environmentally friendly materials can reduce pollution incurred by processing. Also, the manufacturing process must be improved to reduce pollution generated during manufacturing.

So, green manufacturing should focus on two objectives:

First, minimize the use of environmentally-detrimental materials in products to reduce the pollution in the material manufacturing process and the environmental impact after the product's lifecycle expires.

Second, use advanced, energy-saving, and clean production processes to replace traditional high-energy-consuming and high-pollution ones to reduce energy consumption and pollutant discharge.



Innovation in Three Directions Towards the Green Sky Targets

In terms of antennas, the key to achieving the aforementioned green targets lies in architecture, process, and form innovation. These three directions of innovation are closely related to each other rather than being separate. For example, product architecture design and production process support and promote each other. Both are indispensable and need to be developed together.

3.1 Architecture Innovation

The architecture design of antennas is critical to product energy efficiency. It also influences the selection of product components and materials and the production method. Therefore, architecture innovation is the basis of antennas' green innovations.

Figure: Complex internal structure of a conventional antenna

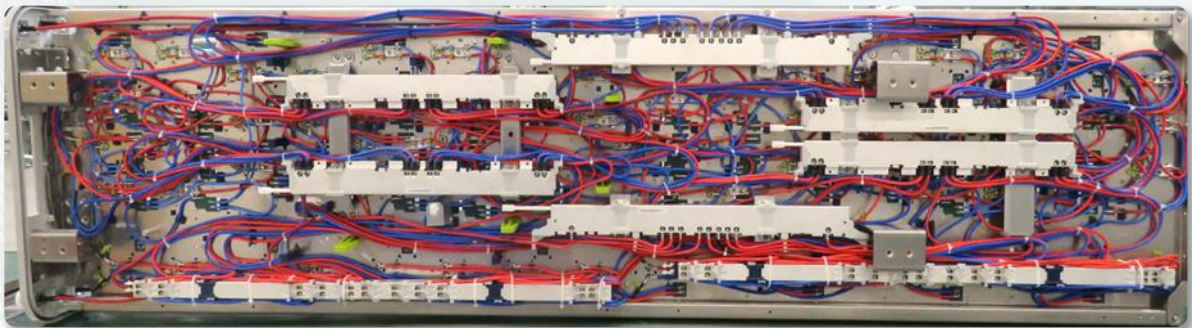

Improve Antenna Energy Efficiency:

Internally, an antenna consists of three main parts: dipole array at the front, and feeding network and driving mechanism at the rear. Driven by the needs for beam downtilting and beamforming, the feeding network of antennas has evolved over the years and become extremely complicated. In a common antenna architecture, a feeding network generally includes components such as phase shifters, power splitters, and combiners — all of which are connected by coaxial cables. After entering the antenna port, an RF signal travels along a complex path to reach the dipole array, which generates electromagnetic wave radiation accordingly.

Complex feeding paths degrade RF energy. This is the main reason why antennas cannot convert all RF energy into electromagnetic radiation energy. Energy loss is related to the access frequency band. Generally, the loss is about 25% on low bands (< 1 GHz), and about 35% on mid-bands (1.7–2.6 GHz). Take the commonly used 2L4H six-band antennas as an example. Their internal overall loss is about 30%, which is significant. Therefore, reducing energy loss is the key to improving the energy efficiency of antennas and the overall energy efficiency of base stations.

To solve the preceding problem, a low-loss, highly integrated internal architecture must be adopted for antennas.

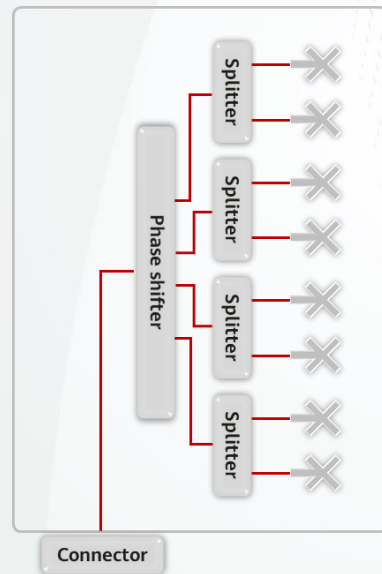
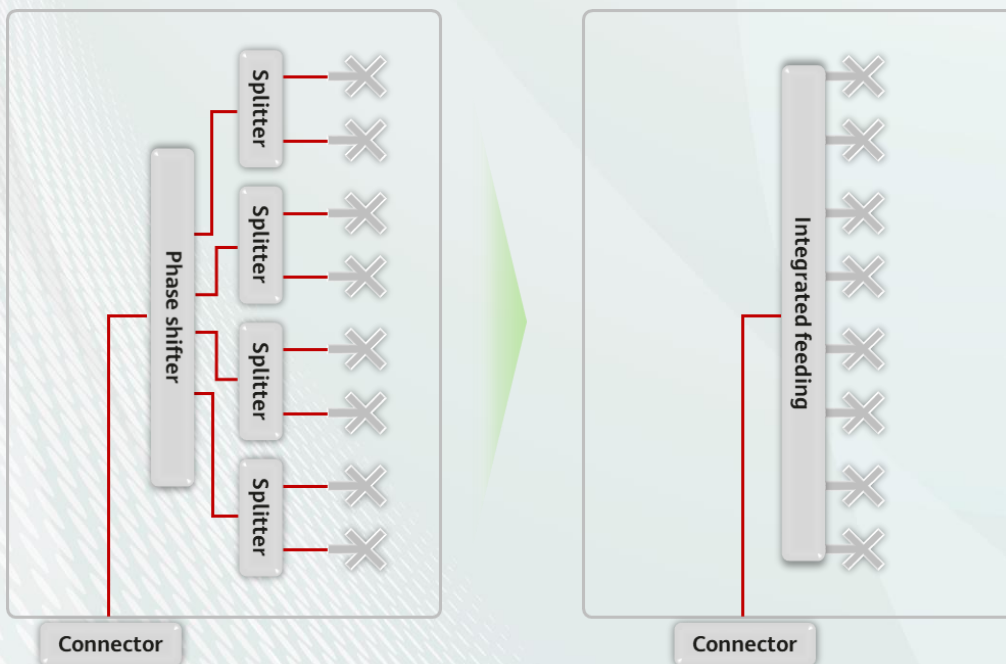

Figure: Energy route inside antennas

For example, the signal direct injection feeding (SDIF) architecture integrates all the scattered components into one, reducing the number of component connections, and replaces coaxial cables with air-type striplines to **integrate the dipole array and feeding network**. As shown in the following figure, the antenna architecture is greatly simplified. This significantly reduces the end-to-end energy loss. Take the 2L4H antennas as an example. The SDIF architecture can reduce their internal overall loss to about 17%.



On the basis of SDIF, antenna ports can be directly integrated into feeding networks. This completely removes the need for cables inside antennas, thereby eliminating cable losses, while maximizing energy efficiency.

In addition to internal losses, external cable losses can be reduced.

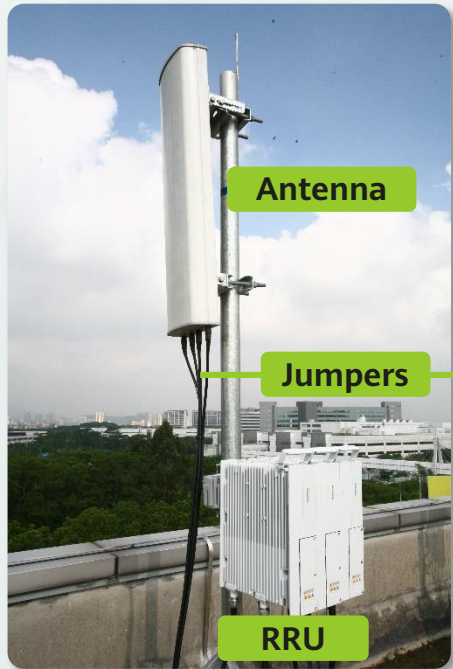

1/2" jumper loss

Jumper length	RF energy loss
2m	6%
4m	11%
6m	16%
10m	25%

Average values at 2.2 GHz

During site deployment, as feeders or jumpers (flexible coaxial cables with small bending radius between RF unit and antenna) are used to connect RF units and antennas to transmit RF energy, the energy loss in feeders or jumpers should be reduced. As shown in the following figure using the 1/2" jumper and 2.2 GHz frequency band as an example, the amount of energy loss on jumpers is related to cable types and lengths, and frequency bands.

The innovation of the internal architecture makes antennas more integrated and thinner. Space that opens up can be used for installing RF units at the back of antennas. In this way, only 0.3 m jumpers are required to connect RF units and antennas, considerably reducing external cable losses.

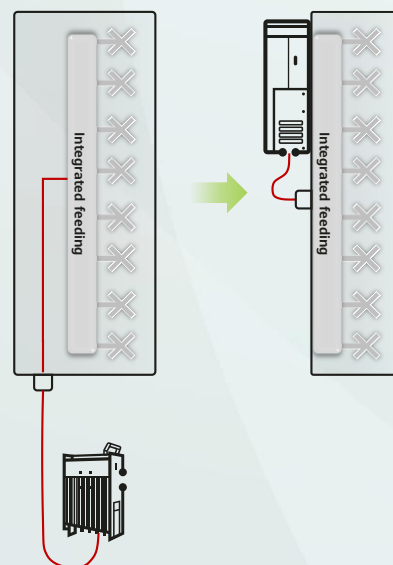

Therefore, the antenna architecture innovation improves the efficiency of not only antennas, but also external RF energy transmission, that is, Antenna & Feeder energy efficiency.

Reduce the Use of Plastics and PCBs

The complex architecture of conventional antennas requires the use of a large number of plastic products and PCBs, such as jackets and dielectric layers of cables, PCB-based power splitters, PCB-based phase shifter striplines, and the supports for securing these components. For example, the total weight of the plastic parts used inside a 2L4H six-band antenna is more than 3 kg. Reducing the use of these plastic materials can contribute significantly to environmental protection.

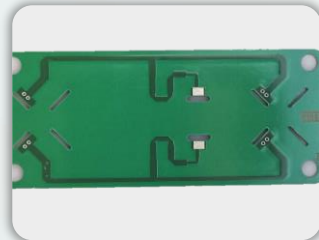

The integrated architecture of antenna arrays and feeding networks noticeably reduces the use of plastic products. As mentioned above, based on the SDIF architecture, RF signals can be transmitted without cables inside antennas. The plastic in the cables is more than 60% of the total used inside antennas. Therefore, cable-free deployment inside antennas can significantly slash the amount of plastic used.

PCB manufacturing produces various kinds of pollutants, including heavy metal ions like copper and nickel, polymer organic matter, and complexing agents. However, effectively recycling waste PCBs is a challenge around the world and discarding them may create secondary pollution. As such, the antenna architecture should be innovated with the target of reducing or even eliminating the use of PCBs. Given that metal materials have a higher recycling rate, air-type striplines made of copper, aluminum, and other metals can be used instead, alleviating the impact on the environment.

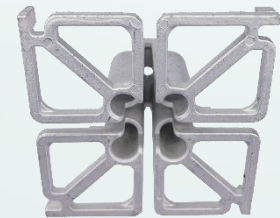

Architecture design, in which the whole picture of antennas' green innovation is planned, is the initial and also most important stage of antenna design.

3.2 Process Innovation

Conventional antenna production consumes a lot of power and can easily produce pollution, especially during the electroplating and soldering processes.

In addition to its high power consumption, electroplating generates a lot of pollution, like water, air, and solid waste pollution. Among these types of pollution, water pollution (mainly containing heavy metal ions, cyanide, acid base, and organic pollutants), air pollution (mainly containing various acid mist and dust), and sludge pollution (mainly containing heavy metals and cyanide) from electroplating wastewater are major environmental problems.



During the production of antennas, soldering generates smoke pollution, which mainly contains heavy metals such as tin and lead, in addition to other harmful substances such as rosin and acid dust. Worse yet, the current soldering process in antenna production mainly involves soldering iron and labor-intensive, manual processes, resulting in low production efficiency.



For these reasons, the innovation objectives of antenna manufacturing process should focus on the elimination of electroplating and soldering, as well as the reduction of power consumption and manual operation.

Taking soldering as an example, laser welding is an advanced and innovative process that can replace conventional soldering, and has great potential in antenna manufacturing. Its advantages include but are not limited to:

- Electroplating of soldering parts is not required, which directly reduces the pollution and power consumption.
- Laser welding directly melts and connects the contact parts of two components. No medium such as tin is required, and therefore no smoke or dust pollution is generated.
- The spatial characteristics of lasers allow for precision soldering, making laser welding an ideal choice for processing of complex antenna components with high precision requirements.
- It can also help facilitate automated manufacturing for higher efficiency.



Figure: laser welding

It should be noted that process upgrade and architecture design innovation are complementary. A new process can be implemented only with a proper architecture design, while new processes are also a necessary condition for implementing a highly integrated architecture. Process innovation is a complex, integrated action, not just the behavior of a single enterprise. It requires product design innovation, investment upgrade of manufacturing equipment, personnel training, and, more importantly, cultivation and investment in the industry chain to achieve end-to-end technology upgrade.

3.3 Form Innovation

Antennas are installed on the top of a site. Due to space restrictions, antennas must be simplified and their configuration capabilities must be continuously improved to support efficient network construction and evolution.

Integrate On-Tower Equipment to Reduce the Number of Boxes:

As networks evolve, spectrum resources continuously increase. This leads to the proliferation of boxes on a site, such as antennas and RF units. To address this challenge, antenna configurations need to be continuously improved. That is, one antenna needs to support all frequency bands to limit the number of antennas on the tower. In this regard, the antenna industry has achieved outstanding results.

However, there are still huge challenges ahead. For example, the deployment of multiple Massive MIMO AAUs on high bands and passive antennas on low- and mid-bands may lead to significantly more boxes on sites.

As shown in the figure below, by 2025, three FDD low bands, three FDD mid-bands, and two TDD bands Massive MIMO may be required in a high-capacity scenario. Based on the current products in the industry, operators would need to install eight boxes in one sector, putting much strain on site load. In many scenarios, operators would have to build a new site to install these devices.

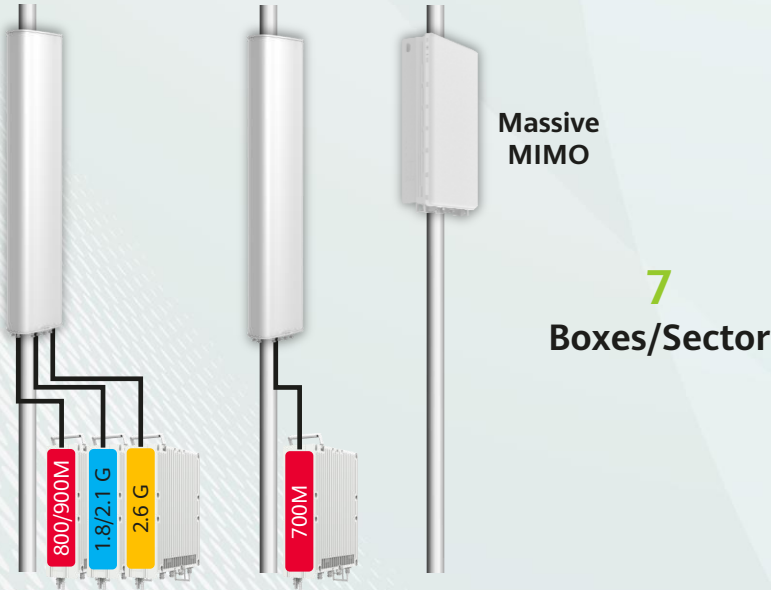



Device integrating on the tower is an effective way to simplify the site. Currently, the A+P integrated antenna mode used in the communications industry is a good example of efficient form innovation. Passive antennas are integrated with Massive MIMO AAUs to simplify the antenna form. Alternatively, RF units can be installed behind passive antennas to form an AAU, which simplifies sites and improves energy efficiency.

Based on these two antenna forms, we can propose a new mode for the future, in which passive antennas will evolve into a tower-mounted device integration center to flexibly integrate massive MIMO AAUs, RF units, TMAs, combiners, and passive antennas of other frequency bands. In this way, sites can be simplified and the number of boxes reduced. In this mode, passive antennas serve as subracks, while other devices on the tower serve as boards.



This requires innovations in electrical and mechanical characteristics of passive antennas, Massive MIMO modules, and RF units to support more flexible combination and integration, simpler installation, and more user-friendly appearance.

Reconfigurable Capabilities Enable Smooth Network Evolution Without Antenna Changing:

Network evolution includes spectrum evolution (e.g. supporting the 700 MHz spectrum), RAT upgrade (e.g. LTE to NR), networking mode evolution (e.g. single-beam cells to multi-beam cells), and multi-antenna evolution (e.g. 4T4R to 8T8R). Conventionally, new antennas need to be added or existing ones need to be replaced to meet new network capability requirements for spectrum and multi-antenna evolution. This requires a large amount of resources and a long construction period.

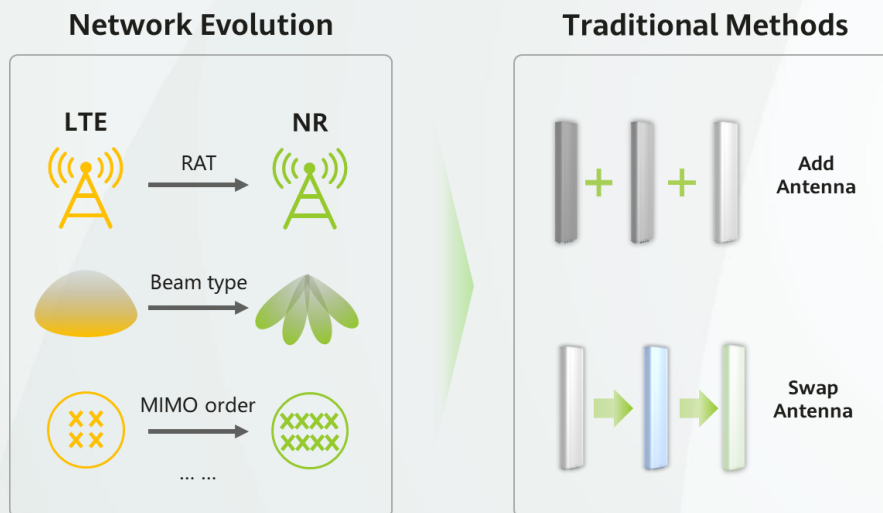

The capabilities of a conventional antenna are usually fixed after the design is complete and cannot be evolved throughout its service life. However, we can address this challenge through the following innovations.

With software-designed antennas, an antenna works with the baseband unit of a base station to change the antenna configuration capability by upgrading the weight of the RF channel. For example, SDA, which has been widely put into commercial use, supports the 4T4R 6-sector networking mode on 4G networks. It can be evolved to support 8T8R 3-sector networking mode on 5G networks with the upgrade of both the antenna and the baseband unit. Continuous R&D is required in this field to explore more flexible evolution paths for the future.

With hardware switch capability, an antenna can change the beam form by adjusting the RF signals on feeding networks based on the coordination of feeding networks and arrays.

The third innovation is modular design. This means that different frequency bands of antennas are designed as independent modules, and several modules can be flexibly combined into one antenna. The module corresponding to each frequency band can be replaced and upgraded separately. In this way, the entire antenna does not need to be replaced during the evolution of a frequency band.

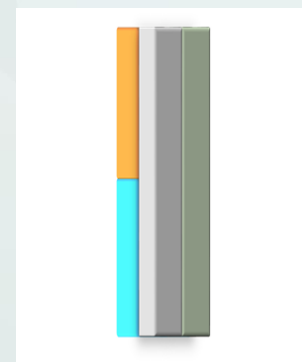
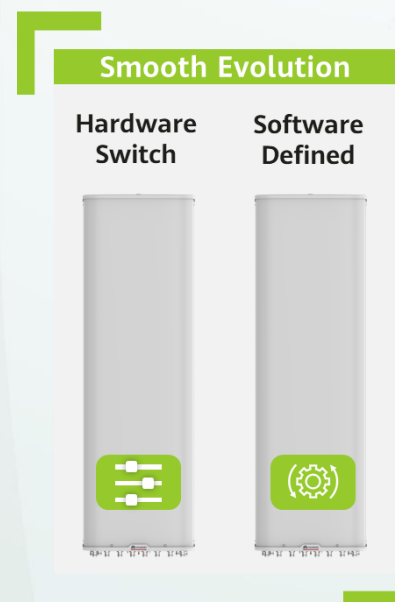

Reconfigurable capability of antennas can reduce the need to add new or replace existing antennas, prolonging the service life and reducing the number of discarded antennas.

04

Targets of Green Sky Program 2025

As demands on networks increase, building green networks is a global priority. Technical development shouldn't come at the cost of our environment. Since antennas are key network devices, it is critical for the antenna industry to facilitate green innovations that cover an entire product's service life.

Therefore, we propose the following targets for antennas' green innovations:

Energy saving: Improving the overall energy efficiency of the antenna & feeder system by 40%; lowering RF power requirements and saving energy for base stations while ensuring network performance.

Green deployment: Halving the number of boxes per frequency band by building antenna capabilities to integrate tower-mounted devices, and enabling smooth evolution of antennas to avoid repeated reconstruction through modular and reconfigurable capabilities.

Green manufacturing: Bringing down resource consumption through innovative architectures and processes to reduce production energy consumption, and eliminating electroplating, soldering, plastics, and PCBs to minimize the environmental impact.

To achieve these targets, antennas must be innovated in terms of architecture, process, and form to pave the way for efficient network evolution and green industry development.



HUAWEI TECHNOLOGIES CO., LTD.

Huawei IndustrialBase

Bantian Longgang

Shenzhen 518129, P. R. China

Tel: +86-755-28780808

www.huawei.com

Trademark Notice

 HUAWEI , HUAWEI ,  are trademarks or registered trademarks of Huawei Technologies Co.,Ltd.

Other Trademarks, product, service and company names mentioned are the property of thier respective owners.

General Disclaimer

The information in this document may contain predictive statement including, without limitation, statements regarding the future financial and operating results, future product portfolios, new technologies, etc. There are a number of factors that could cause actual results and developments to differ materially from those expressed or implied in the predictive statements. Therefore, such information is provided for reference purpose only and constitutes neither an offer nor an acceptance. Huawei may change the information at any time without notice.

Copyright © 2019 HUAWEI TECHNOLOGIES CO., LTD. All Rights Reserved.

No part of this document may be reproduced or transmitted in any form or by any means without prior written consent of Huawei Technologies Co.,Ltd.